

A Beverage Array for 160 Meters

The key to a high score in most 160 meter contests lies in working the greatest possible number of Europeans, since these contacts provide additional multipliers and each is worth considerably more points. Often I've found it extremely difficult to work *any* Europeans from my location in Maryland owing to high levels of interference — both manmade and atmospheric — despite listening on a properly oriented 770 foot Beverage antenna. It seemed evident that I needed something better, and that a receive antenna of Beverages combined in some sort of array might greatly improve matters. This article recounts my quest for such an antenna.

Basic Element

I first explored the choice of basic element using the design in Figure 1. This is the same length as the Beverage I've been using for listening to Europe, although mine does not have sloping sections at each end. I modeled the antenna in *EZNEC 5* as being constructed using #18 copper wire (in practice I use copper-clad steel

wire for its superior strength) over a real/high accuracy ground having a dielectric constant of 13 and a conductivity of 5 mS. A 650 Ω terminating resistor was placed in the center of the short (0.5 foot) vertical wire at the far end, while the source was

placed at the center of the short (0.5 foot) vertical wire nearest the origin (see Figure 1). The resulting azimuth and elevation plots are shown in Figure 2.

It is evident that there are large unwanted side lobes that doubtless contribute to

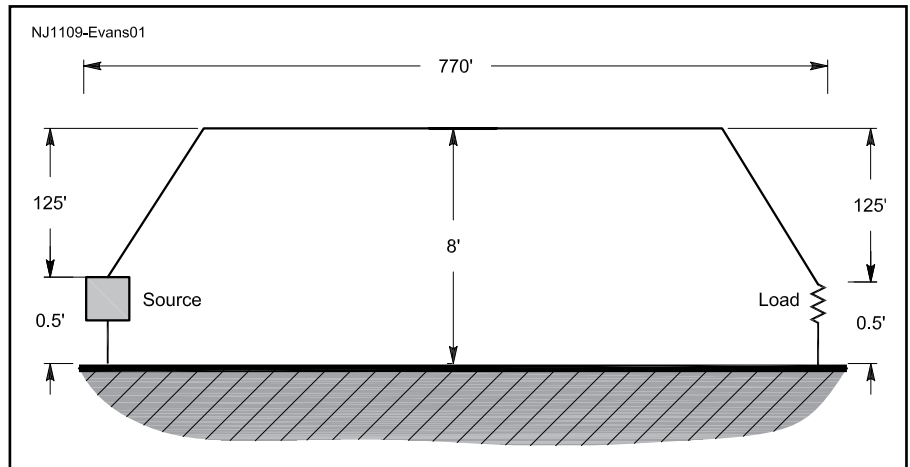

Figure 1 — Arrangement of the wires employed in the 770 foot grounded Beverage model

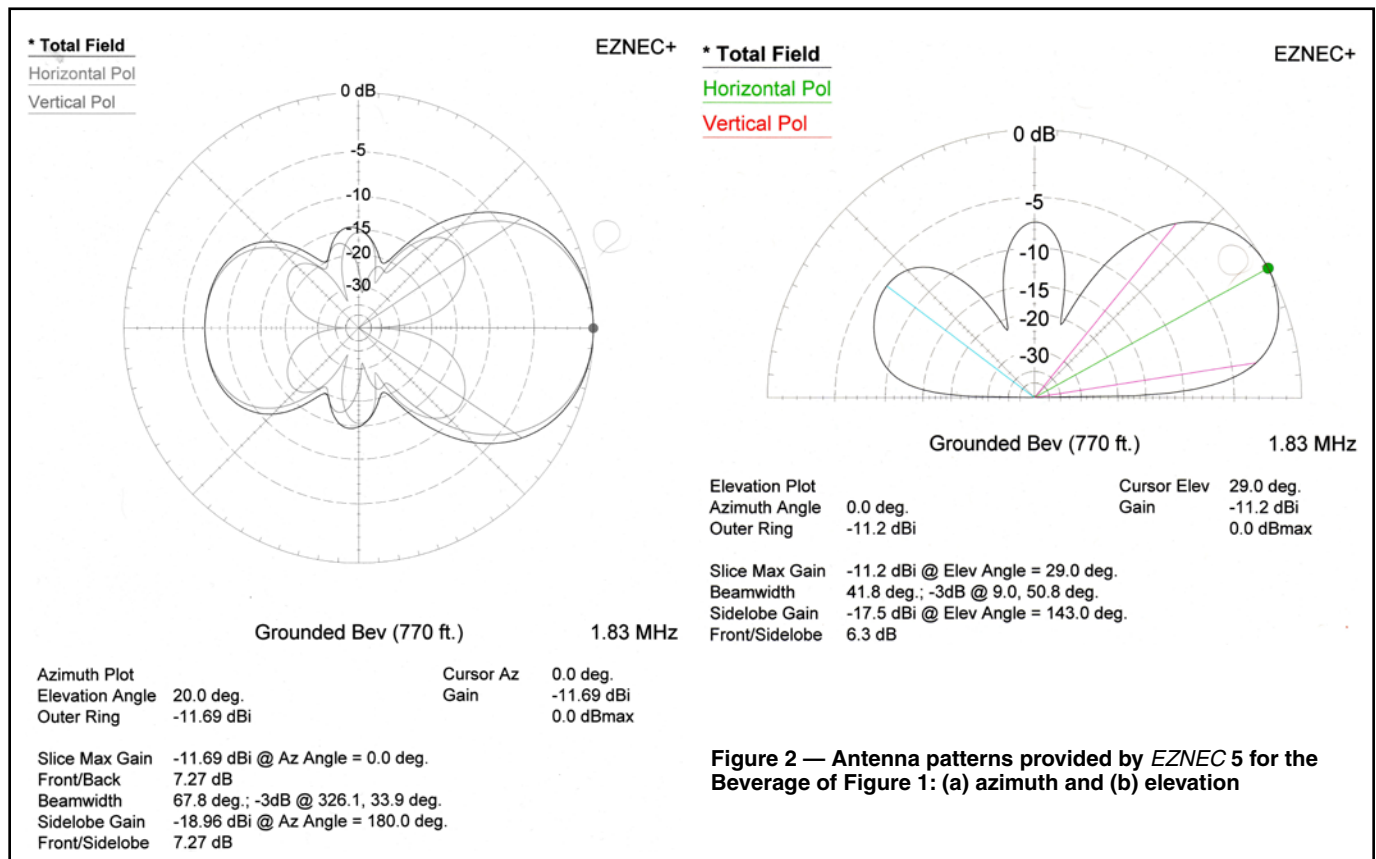

Figure 2 — Antenna patterns provided by *EZNEC 5* for the Beverage of Figure 1: (a) azimuth and (b) elevation

the levels of interference and noise that I experience. (The back lobe of my Europe-pointing Beverage is oriented toward the southwest, a likely vector for thunderstorm interference.) The first step I made in trying to reduce the side lobes was to adopt the ungrounded Beverage design advocated by Beezley¹ (see Figure 3). To unground the antenna simply remove the short vertical wires at either end and move the source and load to the opposite ends of the horizontal wire (ie, the opposite ends of the sloping wires). Figure 4 depicts the resulting antenna patterns, which exhibit a marked improvement in lowering unwanted side lobes. You pay a price for this improvement, however — namely, that the antenna now provides useful performance only on 160 meters unless additional quarter-wave wires are added to the ends, as Beezley discusses.

I next tried varying the length of the horizontal wire of the antenna (see Figure 3) in an effort to achieve further side lobe reduction. It soon became evident that the number of unwanted side lobes generally increases with length. Indeed, only by reducing the length to something approaching one wavelength was it possible to secure a pattern with just one unwanted lobe. Figure 5 shows this case for a 540 foot Beverage. Comparing Figures 4 and 5 we see that shortening the antenna reduces gain (by 2 dB) and raises the

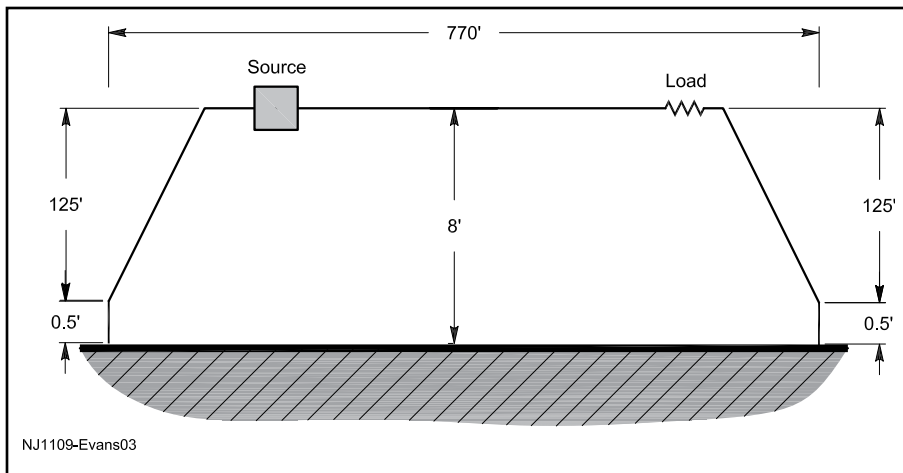

Figure 3 — Arrangement of the wires employed in the 770 foot long ungrounded Beverage model.

elevation angle of the main lobe (by 13°). The loss of gain is unimportant, if the level of unwanted signals entering the side lobes has been reduced by a greater amount. Increasing the elevation angle of the main lobe is possibly of greater consequence. The *High Frequency Terrain Analysis (HFTA)*² program suggests that the arrival angles of 160 meter signals from Europe to the Washington, DC, area are all less than 20°. One must question the validity of simple ray-tracing programs, however, when the frequency of the wave

is close to the gyro frequency. Moreover, some evidence suggests that in many instances 160 meter signals propagate by means of a duct between the nighttime E and F layers and spill out of it at steep angles, particularly around sunrise at the eastern end of the path.

Setting this issue aside, I next explored changing the value of the terminating resistor and found a 2 dB improvement in the F/B ratio when I increased this value to 1000 Ω. This alerted me to the need to vary this value in subsequent designs. The

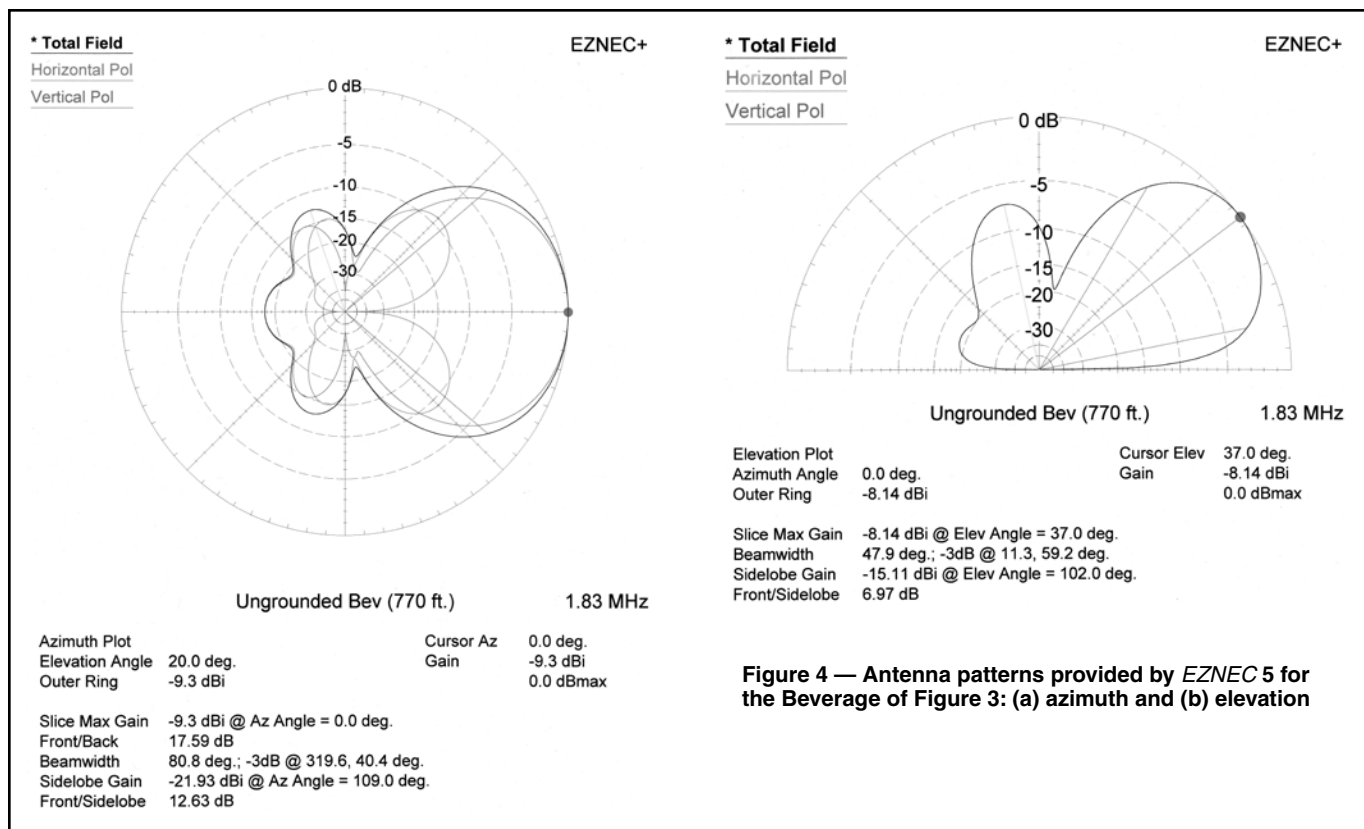

Figure 4 — Antenna patterns provided by EZNEC 5 for the Beverage of Figure 3: (a) azimuth and (b) elevation

discussion that follows focuses on the use of this basic element in a number of Beverage arrays.

Arrays of Two Beverages

Devoldere³ and others have discussed the use of Beverage arrays to improve gain and directivity. My first effort then was to model a pair of one-wavelength, ungrounded Beverages of the type shown in Figure 3. To combine the outputs of the antennas a 600 Ω transmission line was connected to the source position of each element (first segment of the horizontal wire) and terminated on a short vertical wire introduced midway between them, on which the new source was placed. I experimented with changing the termination loads and found a slight improvement in raising the load to a value greater than 650 Ω. I also experimented with adjusting the spacing (in the direction of the y axis in my models) between the two Beverages. I discovered that this had little effect, once they were far enough apart not to couple. Patterns obtained with a separation of 100 feet and termination loads of 1000 Ω showed that the gain had improved, but the front-to-back (F/B) ratio was essentially unchanged.

I was aware that in order to improve the F/B ratio some designers have employed arrangements in which the Beverages are staggered with respect to one another along the x axis of my models (ie, in the direction of desired reception). The editions of *Antennas and Techniques for Low-Band DXing* that I had on hand did not cover this. The author, John V. DeVoldere, ON4UN, informed me that this is discussed in the 4th and 5th editions. Lacking any guidance on this, I simply experimented by moving my two Beverages with respect to one another (along the x axis), while keeping them 100 feet apart (in the y direction) and connected by the same two 600 Ω transmission lines. The latter were kept as short as possible by moving the short vertical source wire to be equidistant from the feed points on the two horizontal wires of the

Beverages. In addition to experimenting with differing amounts of “stagger” I also varied the termination loads. The patterns obtained when one element is advanced 100 feet with respect to the other, and the terminating loads were 750 Ω, exhibited only modest (3 dB) improvement in the F/B ratio.

At this juncture I recognized that in addition to physically staggering the elements it would be necessary to control the phase angles at which they are fed; signals from the forward element must be delayed with respect to those from the rear element. I could achieve this in my model by simply lowering the phase velocity V_p on the 600 Ω transmission line to that element, while maintaining it at a value of 1.0 on the section connected to the rear element. Figure 6 illustrates the further improvement achieved when the phase velocity on the transmission line to the forward element was set at $V_p = 0.5$. I tried other values of V_p before arriving at this one, which seemed to be about optimal.

According to the current data provided by *EZNEC*, the phase difference between the signals arriving at the two elements in this model is 97°. It is evident in Figure 6a that the pattern is no longer symmetrical. The direction of the main beam has been skewed in azimuth (by 9°), and the rearward lobes are asymmetric. The computed F/B ratio (see Figure 6a) therefore exaggerates the level of side lobe suppression achieved, since a side lobe remains that is only ~21 dB below the main lobe.

Arrays of Three Beverages

To restore symmetry to the patterns it is necessary to rearrange the Beverages. Accordingly, I next modeled a three-Beverage array by adding a third Beverage to the model described above. The rearward Beverage is now the center one and is set back (along the x axis) from the two outer elements by 100 feet. The spacing between it and the outer elements (in the y direction) was also set at 100 feet. Initially, I simply connected all feed points together

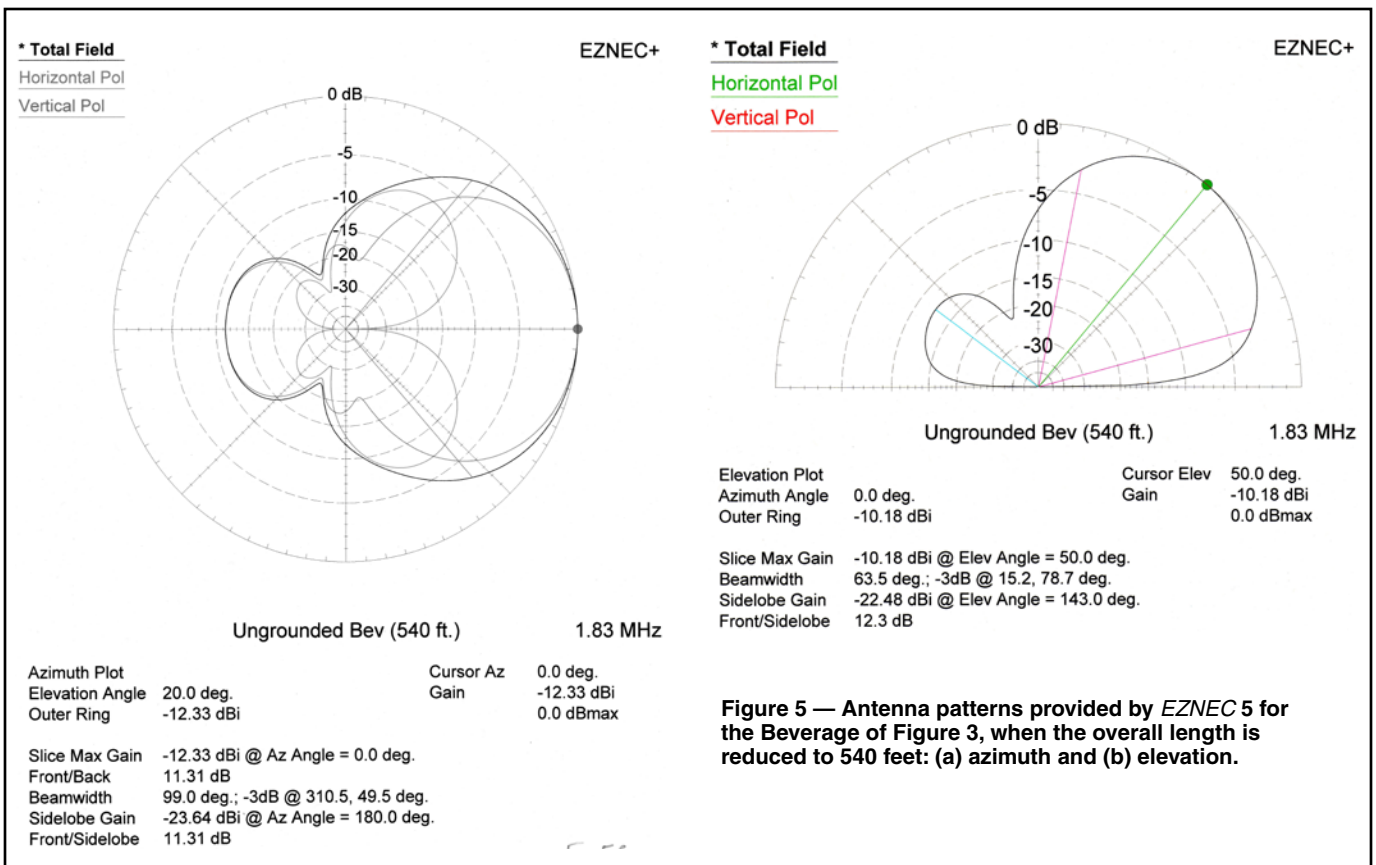
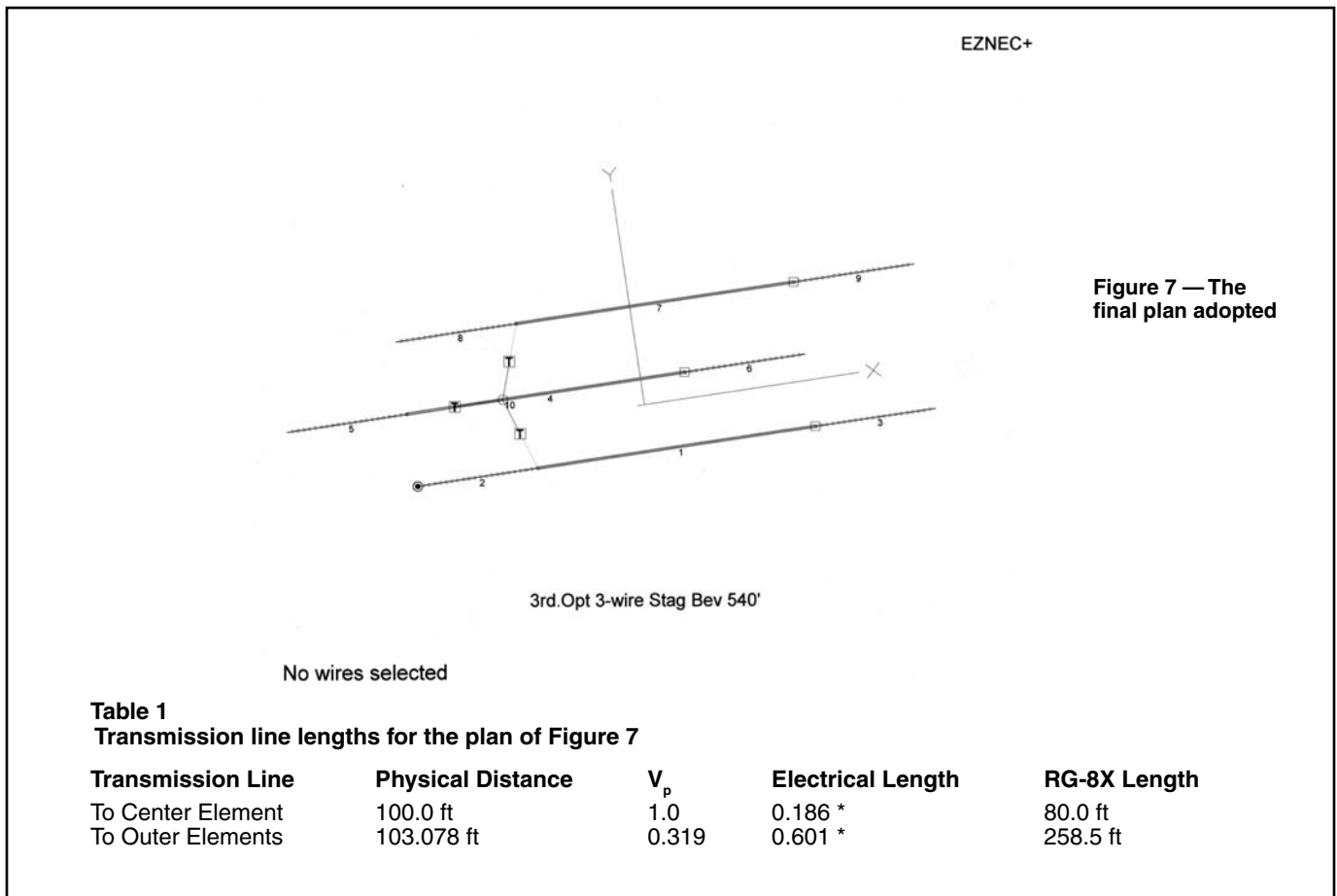
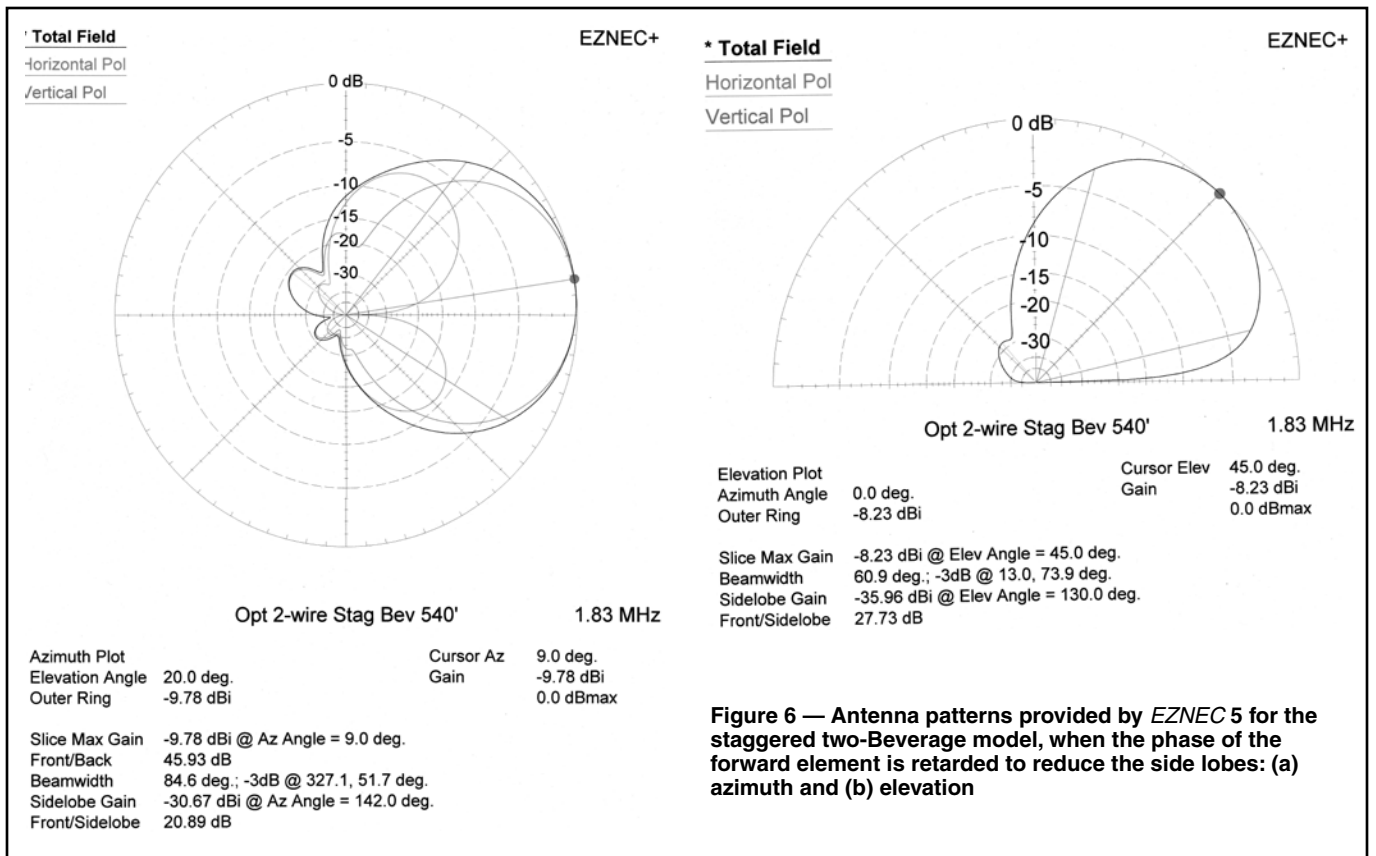

Figure 5 — Antenna patterns provided by *EZNEC 5* for the Beverage of Figure 3, when the overall length is reduced to 540 feet: (a) azimuth and (b) elevation.



using 600 Ω transmission lines. This placed the source for the array on the center element, with the signal delay to the two outer elements set by the length (141.4 feet) of the transmission lines to them. While this arrangement restored symmetry to the patterns, it was clearly not optimal. Once again I explored the effect of changing the terminating loads, but I saw little improvement, so these were left at 750 Ω . Optimizing this three-Beverage array model by changing both the spacing and the amount of “stagger” to 125 feet secured further improvement. This effectively increased the phase delay between the elements.

Optimum Three-Beverage Arrays

In practice, we'd have separate transmission lines connected to each element, so I modeled such a scheme next. I reverted to the arrangement where the Beverages are separated by 100 feet and the center antenna is staggered back by 100 feet with respect to the outer pair. The source was now placed on a wire below the center Beverage and 100 feet from its feed point. This minimized the length of transmission lines to the outer elements. It was now possible to separately adjust the phase velocity V_p on each transmission line in an effort to cancel the unwanted back lobe. The best F/B ratio was obtained at a setting of $V_p = 0.43$ on the transmission lines to the outer elements, leaving the center element at $V_p = 1.0$. I then sought further improvement by changing the terminating loads, achieving the best F/B ratio (27 dB) by increasing these to 1100 Ω . The current on the center Beverage was computed to be 0.34 A versus 0.26 A on each of the outer elements, and the phase difference was on the order of 88°.

I had achieved comparable performance with the simple model described above when I increased the stagger and the separation to 125 feet. Accordingly, I went back to those dimensions and tried further optimization. While increasing the stagger to 125 feet appeared to improve matters, little seemed to be gained by

increasing the separation.

Figure 7 shows my final layout in plan view. The outer Beverages have been advanced with respect to the center one by 125 feet. The source position wire (#10) remains below the center wire and 100 feet from its feed point (on the first segment of the horizontal wire). I first adjusted V_p on the transmission lines to the outer elements and achieved a F/B ratio of ~30 dB when these were set to $V_p = 0.319$. Next, I tried changing the terminating loads and raised the F/B ratio to almost 40 dB by increasing these to 1400 Ω (Figure 8). Note that compared with a single Beverage of the same length (Figure 5a) the beamwidth has been reduced from 100° to 86.5° (Figure 8a), and the gain increased by 3.5dB. The current ratio between the wires is now 2:1, and the phase difference is 87°. To explore how frequency-sensitive the design is, I ran the model at 1.85 MHz, whereupon the F/B ratio dropped to ~35 dB, and at 1.87 MHz, where it became 31 dB — good numbers by any standard.

It's unclear whether equivalent performance could be achieved using less real estate, ie, with less separation between the antennas. I leave this to other modelers to explore. I was not able to reproduce the patterns of Figure 8 at a spacing of 75 feet, but that may only reflect a lack of persistence on my part.

Lengthening the Optimum-Design Array

To test whether it's really necessary to use short (540 feet) Beverages to achieve the good patterns depicted in Figure 8, I ran one additional case. I arbitrarily lengthened the 290 foot horizontal wires in my model (Figure 7) by 200 feet, yielding Beverages with an overall length of 740 feet. I hoped this would increase the gain and lower the elevation of the main beam (which it did). A rear-facing lobe now appeared, and the F/B ratio was 20.27 dB. By adjusting the termination loads (down to 800 Ω) and the phase velocity on the transmission lines to the outer elements (to $V_p =$

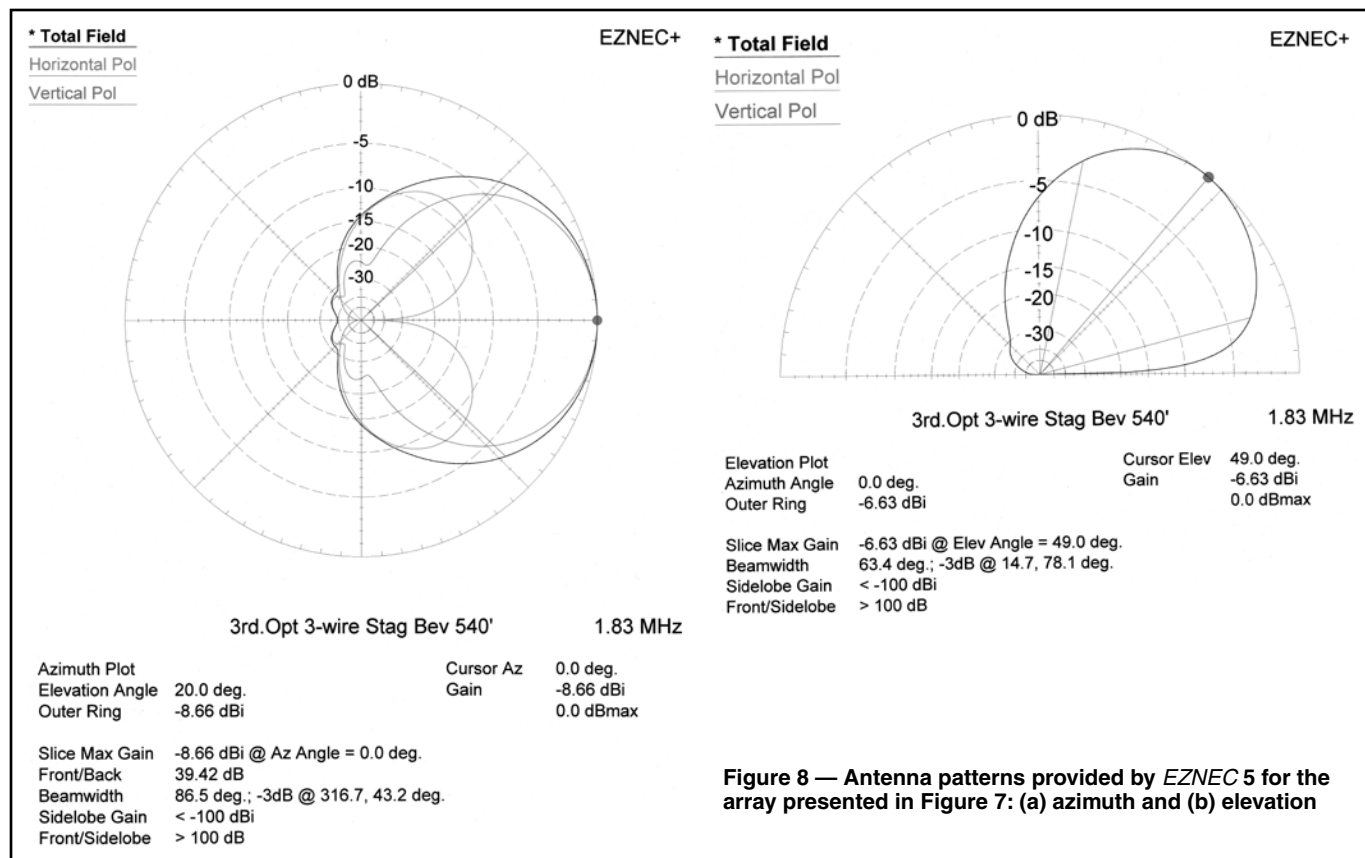

Figure 8 — Antenna patterns provided by EZNEC 5 for the array presented in Figure 7: (a) azimuth and (b) elevation

0.33) I was able to raise the F/B ratio to a respectable 27.8 dB. That's misleading, however, as this side lobe in the y direction is only 21 dB below the main lobe. Figure 9 shows a 3D plot of the pattern, making it evident that we now have a single, large, high-elevation, back lobe.

In sum, it would appear that moving Beverages with respect to one another can be effective in minimizing the strength of unwanted lobes in the same plane as the center Beverage (x direction in my models) but not lobes that are orthogonal (ie, in the y direction). Conceivably, these too could be reduced or cancelled using yet more elements in the array, but I have not explored this.

Practical Considerations

The height of the horizontal wires in all models was held at 8 feet. This practical value allows deer to wander through without causing damage (to the wire or to the deer, which are plentiful where I live.) The sloping portions are a different matter, however, but it may be possible to flag them in some fashion. The chief difficulty in converting the design of Figure 7 to something practical lies in replacing the 600 Ω transmission lines used in the model with transformers and coax feed lines connected to a three-way combiner. (A suitable 50 Ω combiner is available from Array Solutions, www.arrayolutions.com.)

The good performance exhibited in Figure 8 derives in large measure from the 2:1 current ratio on the wires and the nearly 90° phase difference. These in turn appear to be set by the electrical length of the transmission lines and, to a lesser extent, by the termination resistors. Assuming the transformers inserted at the beginning of the horizontal wires provide a good match to 50 Ω , the remaining requirement would be to keep the electrical lengths the same as in the model. Table 1 summarizes the lengths involved when RG-8X (Belden 9258) coax is used ($V_p = 0.80$). The 50 Ω three-way combiner now has to be less than 80 feet from the transformer feeding the center Beverage, thereby increasing the distance to the feed points on the outer Beverages to perhaps 112 feet. The coax required to connect to the outer Beverages to the three-way combiner needs to be 258 feet long (Table 1) — a considerably greater distance — so there should be no difficulty in converting from the 600 Ω transmission lines of the model to more practical 50 Ω coax and 12:1 step-up transformers.

The loss in 258 feet of RG-8X to the outer elements would be 1.26 dB, as opposed to 0.4 dB (in 80 feet) to the center one, and this will somewhat increase the current ratio on the wires. Inserting

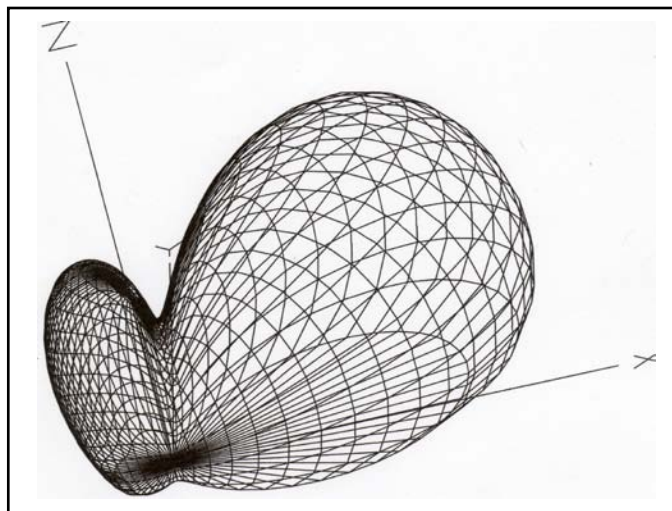

Figure 9 — A three-dimensional depiction of the antenna pattern of the array lengthened by 200 feet (see text).

losses in the model of 1.25 dB/100 feet for the transmission lines to the outer elements and 0.4 dB/100 feet for the one connected to the center element (ie, to match the total attenuation expected) lowered the F/B ratio to ~39 dB. This suggests that RG-8X can be employed with only a slight loss in performance. It would probably be undesirable to employ cables with substantially greater loss, however. I have not had an opportunity to erect the array described here, since a wheat crop is growing in the field where it would go, but I intend to do so at the first opportunity.

Notes

- ¹ Beezley, B., K6STI, "Ungrounded Beverage Antennas," *More Wire Antenna Classics Vol 2*, pp 8-1 to 8-4. ARRL (1999).
- ² HFTA program by D. Straw, N6BV, *ARRL Antenna Book* (19th ed), pp 3-4 to 3-23. ARRL (2000).
- ³ Devoldere J., ON4UN, *Antennas and Techniques for Low-Band DXing* (2nd ed). ch 7. ARRL (1994).

NCJ